

DSS 1064-3000

Diode pumped passively Q-switched solid state laser

- 1064 nm
- single pulse
- < 2.5 ns
- 1 – 80 Hz
- > 2500 μ J

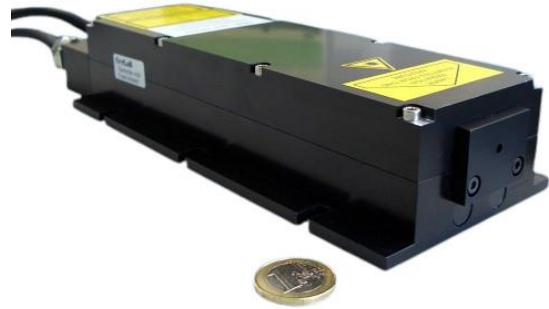

biology · biomedicine · chemistry · analytics

Optical Data	Wavelength	1064 nm
	Spatial Mode	TEM ₀₀
	Beam Divergence (full angle)	< 9 mrad
	Beam Ellipticity	< 2:1
	Waist Diameter	600 ± 150 μ m (located at about 110mm inside the laser head)
	Beam Diameter	1200 ± 400 μ m (at laser exit)
	Peak Power	> 1250 kW @ 20 Hz
	Pulse Energy	> 2500 μ J @ 20 Hz
	Pulse Repetition Rate (with external trigger)	1 - 80 Hz
	Pulse Width (FWHM)	< 2.5 ns
	Polarization Ratio	> 50:1, vertical
	Long term pulse energy stability (6 hours) ¹⁾	< ± 6 %
	Pulse-To-Pulse Stability ²⁾	< 5 % rms
	Laser Classification	3B / IIIb
Optical Output	Free Beam	
Electrical Data	Electrical Power Consumption	< 150 W
	Line Voltage	100 - 240 V AC (50-60 Hz) or 24 V DC
Interface	RS 232, USB	
Miscellaneous	Warm-up Time	< 15 min
	Operating Temperature	18 - 38 °C
	Laser Head Size	217 x 65 x 45 mm (core dimensions)
Options	SMA-connector for fiber with core diameter \geq 600 μ m	
	Synchronization signal output (rise time < 2 ns)	
	Manual shutter or electrical beam blocker	
	Manual or electrical attenuator	
	Stand Alone System (incl. key-switch, heat sink, manual shutter; CDRH compliant)	
	Heat sink with fan (recommended for repetition rates > 20 Hz)	
¹⁾ Drift over 6 hours, energy averaged over 10 sec after 5 min of continuous operation, temperature variation < 3 °C/hour. ²⁾ RMS over 1000 pulses after 5 min of continuous operation.		

Laser Head and Controller

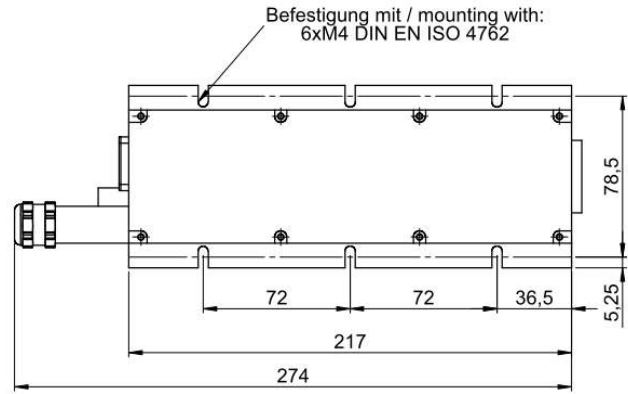
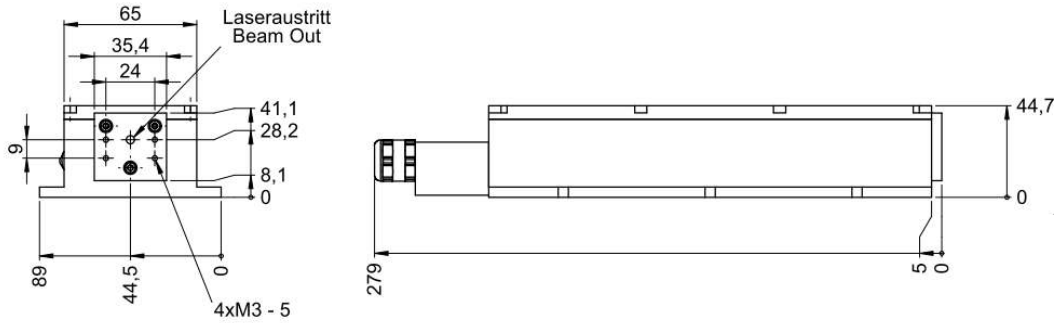

OEM-Controller

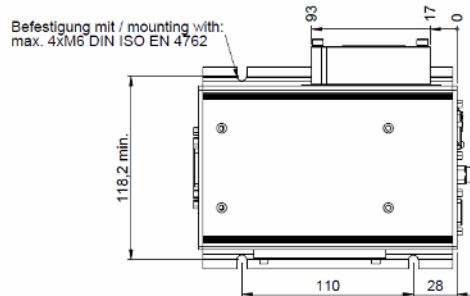
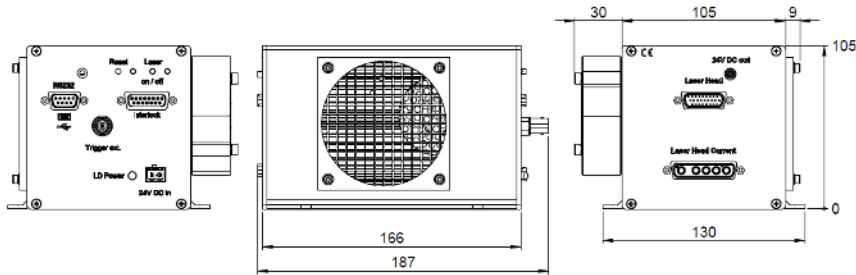

Laser Safety Labels

The DSS1064-3000 lasers are class 3B / IIIb according to IEC 60825-1:2014

<p>wavelength: 1064 nm max. output: 4 mJ pulse duration: < 2.5 ns max. repetition rate: 80 Hz</p> <p>Complies with IEC 60825-1:2014 Complies with 21CFR 1040.10 and 1040.11 except for deviations pursuant to Laser Notice No. 60, dated July 26, 2001</p>	<p>WARNING - INVISIBLE LASER RADIATION AVOID EXPOSURE TO BEAM</p> <p>CLASS 3B LASER PRODUCT</p>	<p>IS EMITTED FROM THIS APERTURE</p> <p>LASER RADIATION</p>
---	---	---

