

FQSS 266-200

Diode pumped passively Q-switched solid state laser

- 266 nm
- single pulse
- < 1.5 ns
- 1 – 60 Hz
- > 200 μ J

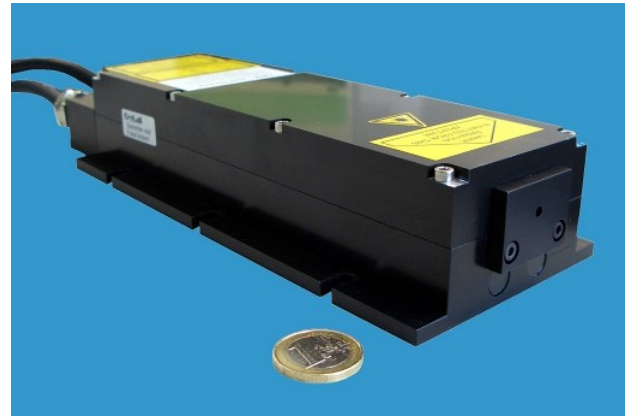

biology · biomedicine · chemistry · analytics

Optical Data	Wavelength	266 nm
	Beam Divergence (full angle)	< 3.0 mrad
	Beam Ellipticity	< 1.5 : 1
	Waist Diameter	500 \pm 150 μ m (located at about 110mm inside the laser head)
	Beam Diameter	800 \pm 300 μ m (at laser exit)
	Peak Power	> 130 kW @ 20 Hz
	Pulse Energy	> 200 μ J @ 20 Hz
	Pulse Repetition Rate (with external trigger)	1 - 60 Hz
	Pulse Width (FWHM)	< 1.5 ns
	Polarization Ratio	> 100:1, vertical
	Long term pulse energy stability (6 hours) ¹⁾	< \pm 5 %
	Pulse-To-Pulse Stability ²⁾	< 3 % rms
	Laser Classification	4 / IV
	Residual Emission	< 0.5 mW @ 1064 nm < 0.1 mW @ 532 nm
Optical Output	Free Beam	
Electrical Data	Electrical Power Consumption	< 90 W
	Line Voltage	100 - 240 V AC (50-60 Hz) or 24 V DC
Interface	RS 232, USB	
Miscellaneous	Warm-up Time	< 10 min
	Operating Temperature	18 - 38 °C
	Laser Head Size	217 x 65 x 45 mm (core dimensions)
Options	Synchronization signal output (rise time < 2 ns)	
	Manual shutter or electrical beam blocker	
	Manual or electrical driven wavelength switch 266 nm / 532 nm	
	External telescope (e.g. M=5)	
	Manual or electrical attenuator	

¹⁾ Drift over 6 hours, energy averaged over 10 sec after 5 min of continuous operation, temperature variation < 3 °C/hour.

²⁾ RMS over 1000 pulses after 5 min of continuous operation.

Laser Head and Controller

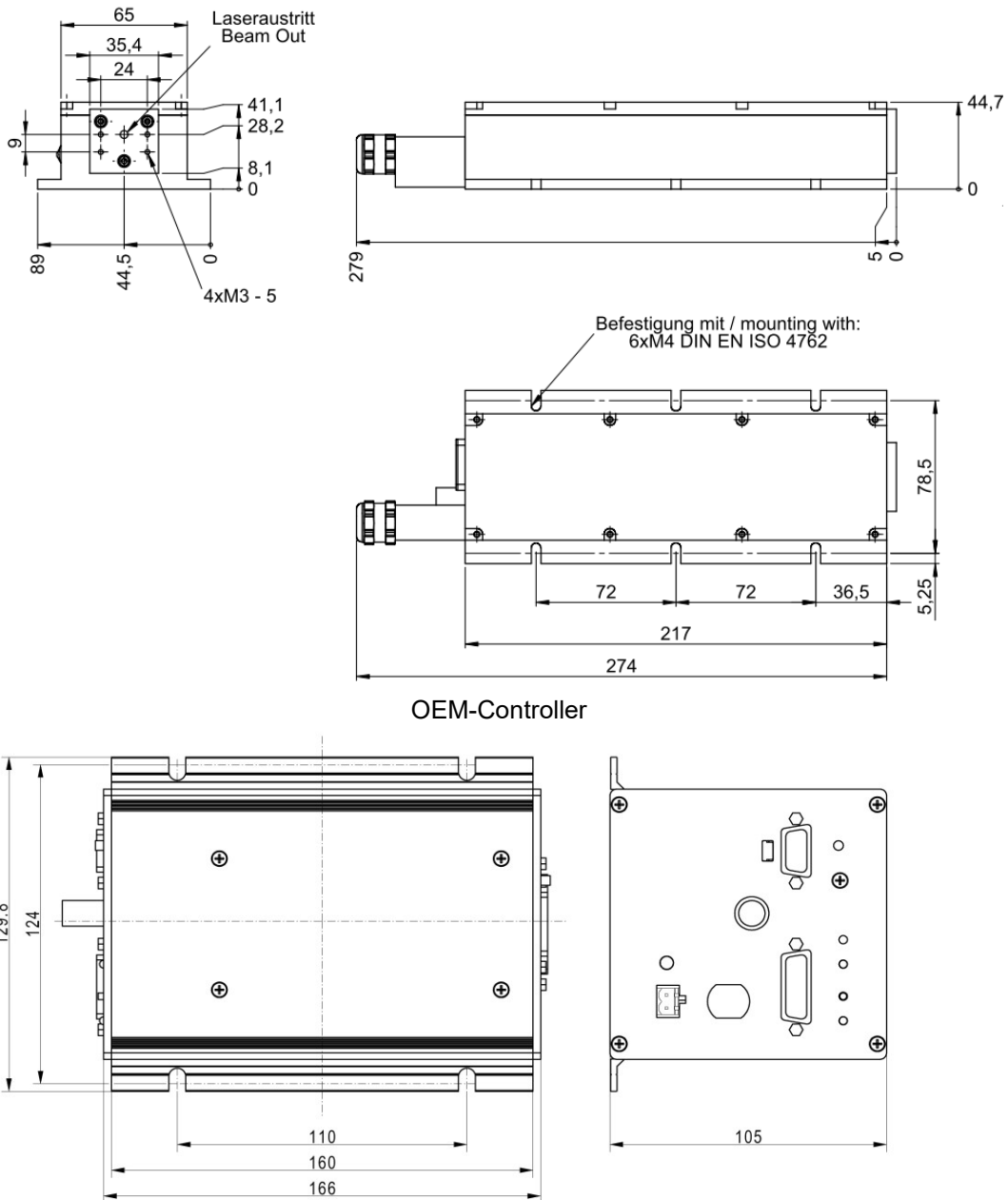

Laser Safety Labels

The FQSS266-200 lasers are class 4 / IV according to IEC 60825-1:2014

<p>wavelength: 266 nm max. output: 400 µJ pulse duration: <1.5 ns max. repetition rate: 60 Hz</p> <p>Complies with IEC 60825-1:2014 Complies with 21CFR 1040.10 and 1040.11 except for deviations pursuant to Laser Notice No. 50, dated July 26, 2001</p>	<p>DANGER - INVISIBLE LASER RADIATION AVOID EYE OR SKIN EXPOSURE TO DIRECT OR SCATTERED RADIATION</p> <p>CLASS 4 LASER PRODUCT</p>	<p>IS EMITTED FROM THIS APERTURE</p> <p>LASER RADIATION</p>
---	--	---

