

eMOPA 355-100

Diode pumped passively Q-switched solid state laser

- 355 nm
- Single Pulse
- 0.9 - 1.3 ns
- single shot (pulse on demand) – 1 kHz
- > 100 μ J
- External / Internal Trigger



biology · biomedicine · chemistry · analytics

Optical Data	Wavelength	355 nm
	Peak Power	> 80 kW @ 1000 Hz
	Pulse Energy	> 100 μ J @ 1000 Hz
	Beam Divergence (full angle)	< 3.5 mrad
	Beam Ellipticity	< 2:1
	Beam Diameter	450 \pm 150 μ m (at laser exit)
	Spatial Mode	TEM ₀₀
	Pulse Repetition Rate (with external trigger)	single shot (pulse on demand) – 1 kHz
	Pulse Width (FWHM)	\leq 0.9 – 1.3 ns
	Polarization Ratio	> 100:1, vertical
	Pulse Energy Drift over 6h ¹⁾	< \pm 3 %
	Pulse-to-Pulse Energy Stability ²⁾	< 2%
Laser Classification	4 / IV	
Optical Output	Free Beam	
Electrical Data	Electrical Power Consumption	< 100 W
	Line Voltage	90 - 265 V AC (50-60 Hz)
Interface	USB / RS232	
	BNC connector for external triggering (TTL)	
	SMB connector for 24 V DC output	
Miscellaneous	Warm-up Time	< 10 min
	Operating Temperature	22 - 32 °C
	Laser Head Size	56 x 140 x 265 mm (H x W x L)
	Controller (Stand-Alone Unit Size)	129,5 x 177 x 180 mm (H x W x L)
Options	Multimode fiber coupling	
	Synchronization signal output (rise time < 1.5 ns)	
	Electrical or manual wavelength switch (355nm – 532nm) or electrical beam blocker	
	External telescope (beam expander) / Electrical or manual attenuator	
		¹⁾ Averaged over 10s after 10min of continuous operation @ 1kHz activated closed loop control
		²⁾ Over 1000 pulses @ 1kHz after 10min of continuous operation

Dimensions

Laser Head:

265 x 140 x 56 mm

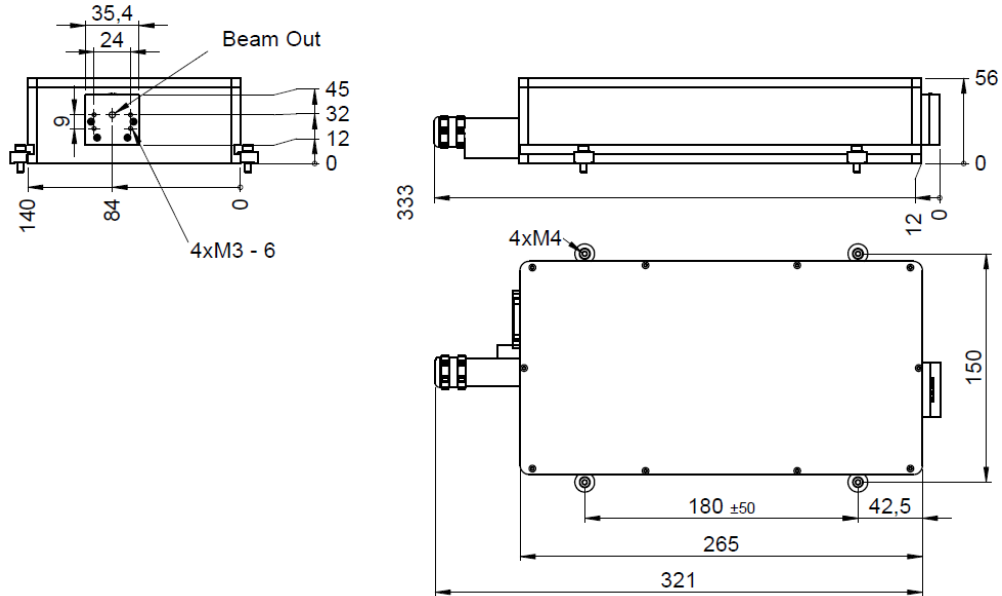

Controller OEM:

166 x 144 x 105 mm

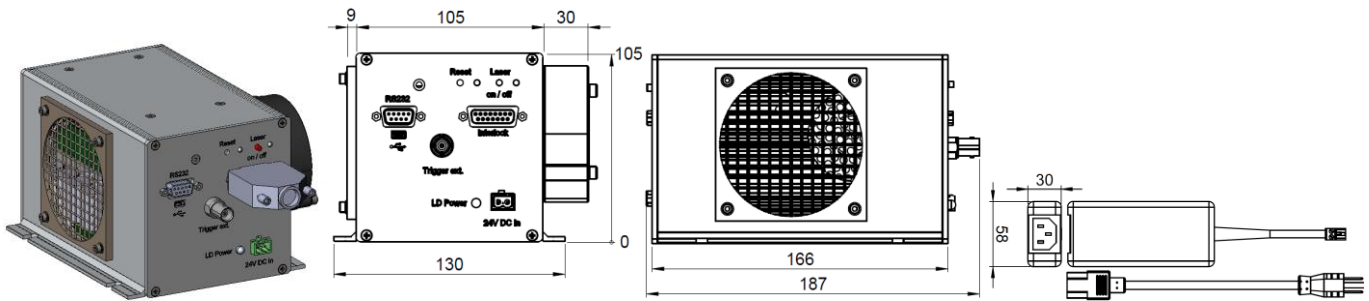

Controller Stand-Alone:

180 x 177 x 129.5 mm

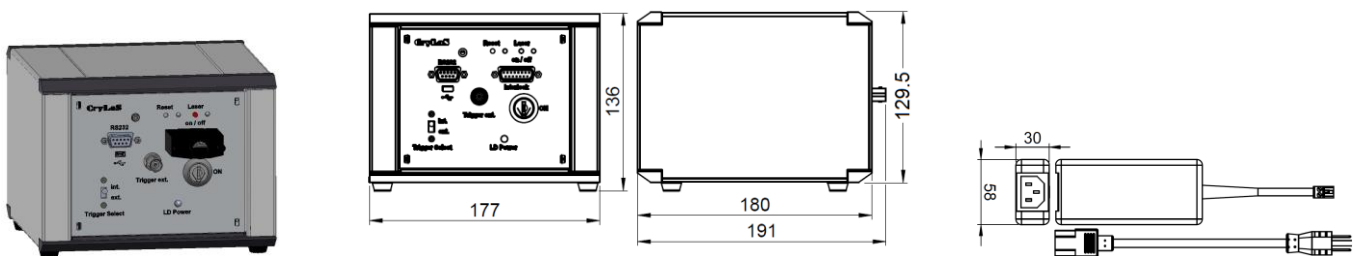

Laser Safety Labels

The eMOPA 355-100 lasers are class 4 according to IEC 60825-1

OEM Laser Device
 Caution! It is designed for use solely as a component and therefore does not comply with 21CFR 1040.10 and 1040.11
 Complies with IEC 60825-1:2014

wavelength: 355 nm
 max. Output: 390 µJ
 pulse duration: <1.2 ns
 max. repetition rate: 2000 Hz

DANGER - INVISIBLE LASER RADIATION
 AVOID EYE OR SKIN EXPOSURE TO DIRECT OR SCATTERED RADIATION

CLASS 4 LASER PRODUCT



© Jan. 2019, Rev 1.2, CryLaS GmbH. All rights reserved.
 Product specifications are subject to change without notice